

KINETOSTATIC ANALYSIS OF THE PRECOMPACTION MECHANISM IN MUNICIPAL SOLID WASTE COLLECTING EQUIPMENT

/

ANALIZA CINETOSTATICĂ A MECANISMULUI DE PRECOMPACTARE LA MAȘINILE DE COLECTAT DEȘEURI MENAJERE

Moise V.¹⁾, Voicu Gh.*¹⁾, Lazea M.²⁾, Stoica D.¹⁾, Popa L.³⁾, Tudor P.¹⁾, Ungureanu L.¹⁾ ¹

¹⁾ University Politehnica of Bucharest / Romania; ²⁾ CCR Romania; ³⁾ INMA Bucharest / Romania

*) Corresponding author: Tel: 0724715585; E-mail: ghvoicu_2005@yahoo.com

DOI: <https://doi.org/10.35633/inmateh-60-33>

Keywords: municipal waste, garbage truck, precompacting mechanism, kinetostatic analysis

ABSTRACT

In the paper is done the kinetic analysis of the mechanism for municipal solid waste takeover and precompaction, of specific equipment for its collection and transport.

The corresponding dimensioning of the actuation mechanism elements shall be made only after the determination of the forces and moments acting on them. The determination of the forces and moments acting on the elements of the mechanism is done by kinetostatic analysis. For the kinetostatic analysis of the mechanism, the applied and inertial forces in the centres of gravity of the elements are reduced, after which the procedures made for each structural group in the composition of the mechanism are applied. Finally, the driving forces are obtained to be applied in the translational couplings (hydraulic cylinders) for setting the mechanism in motion. For the accuracy of the calculation, the driving forces are determined by the virtual exponents' method too.

REZUMAT

În lucrare se face analiza cinetostatică a mecanismului de preluare și precompactare a reziduurilor menajere, de la o mașină specifică pentru colectarea și transportul acestora. Dimensionarea corespunzătoare a elementelor mecanismului de acționare se face numai după stabilirea forțelor și momentelor care acționează asupra acestora. Determinarea forțelor și momentelor care acționează asupra elementelor mecanismului se face prin analiza cinetostatică. Pentru analiza cinetostatică a mecanismului se procedează la reducerea forțelor aplicate și a forțelor de inerție în centrele de greutate ale elementelor, după care se apelează procedurile realizate pentru fiecare grupă structurală din componența mecanismului. În final se obțin forțele motoare care trebuie aplicate în cuplele de translație (cilindrii hidraulici), pentru punerea în mișcare a mecanismului. Pentru corectitudinea calculului se determină forțele motoare și prin metoda puterilor virtuale.

INTRODUCTION

Garbage trucks for collecting municipal solid waste shall be equipped with mechanisms to retrieve and pre-compact the residues discharged from the special pre-collection containers. Most mechanisms of this kind are located at the back of the machines, realizing, together with the compaction plate inside the equipment collection container, the compaction of the loaded residues. This compaction occurs progressively as the pickup mechanism brings material to the loading area. Most of the pickup and pre-compacting mechanisms are flat mechanisms with articulated bars, the elements of which are operated with hydraulic cylinders. In figure 1, the kinematic scheme of the system for collecting and pre-compacting the household material introduced into the takeover tank in the pre-collection containers is presented (Voicu Gh., Lazea M., Zabava B.S., Tudor P., Moise V., 2019; Voicu Gh., Lazea M., Tudor P., Zabava B.St., Moise V., 2019).

¹ Moise V., Prof. Ph.D. Eng.; Voicu Gh., Prof. Ph.D. Eng.; Lazea M., Ph.D. Stud.; Popa L., Ph.D. Eng.; Tudor P., Lect. Ph.D. Eng.; Dugășescu I., Lect. Ph.D. Eng.; Ungureanu L., Lect. Ph.D. Eng.

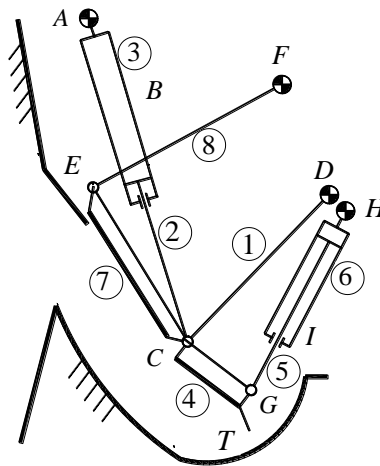

Fig. 1 – Kinematic scheme of waste pre-compaction mechanism

After the structural and kinematic analysis of the mechanism, we pass to the kinetostatic analysis, that is, the determination of the forces and moments acting on the kinematic elements.

The kinetostatic analysis of the mechanism comprises several stages, namely:

- a) Kinetostatic study of each modular group in part;
- b) Elaborating the calculation program for determining the reactions of all kinematic joints of the mechanism, as well as the driving forces in *B* and *I* active couplings (Demidovitch B., Maron I., 1987; Dorn W.S., Mc Cracken D.D., 1976; Moise V., Maican E., Moise Șt. I., 2003; Moise V., Maican E., Moise Șt.I., 2016).
- c) Drawing the corresponding reaction hodographs of joints *A* and *D*;
- d) Drawing the driving forces diagrams of the *B* and *I* translation kinematic coupling;
- e) The tabular presentation of the shares in the joints *A*, *D* and *H* for 81 positions of the mechanism elements.

MATERIAL AND METHODS

1. Kinetostatic analysis of the mechanism

The kinetostatic analysis of the mechanism starts from the initial position, that is, the position in which hydraulic cylinders 2-3 and 5-6 are in initial position (Fig. 2).

For the kinetic analysis of the mechanism, proceed to reduce the applied and inertial forces in the centres of gravity of the elements, after which the functions corresponding to each structural group are used. It is noted that the kinetostatic analysis is done in inverse kinematic analysis, i.e. from the last kinematic analyzed structural group (RRTaR motor dyad (4, 5, 6)) and ending with the first group (RRTaR motor group (1, 2,3)), (Artobolevski I.I., 1977; et al, 2003; Moise V., Simionescu I., Ene M. et al, 2008; Moise V., Simionescu I., Ene M. et al, 2015; Moise V., Simionescu I., Ene M., 2018; Pelecudi Chr., Maroș D., Merticaru V., et al, 1985; Simionescu I., Moise V., 1999).

Motor group RRTaR (4,5,6)

On the elements of the motor dyad RRTaR(4,5,6) act (Fig.3,a):

- Gravity forces:

$$\bar{G}_4 = -m_4 \bar{g}, \bar{G}_5 = -m_5 \bar{g}, \bar{G}_6 = -m_6 \bar{g}$$

- Inertial forces:

$$\bar{F}_{i4} = -m_4 \bar{a}_{G4}, \bar{F}_{i5} = -m_5 \bar{a}_{G5}; \bar{F}_{i6} = -m_6 \bar{a}_{G6}$$

- The resultant moments of the inertial forces:

$$\bar{M}_{i4} = -IG_4 \cdot \bar{\varepsilon}_4, \bar{M}_{i5} = -IG_5 \cdot \bar{\varepsilon}_5, \bar{M}_{i6} = -IG_6 \cdot \bar{\varepsilon}_6 \tag{3}$$

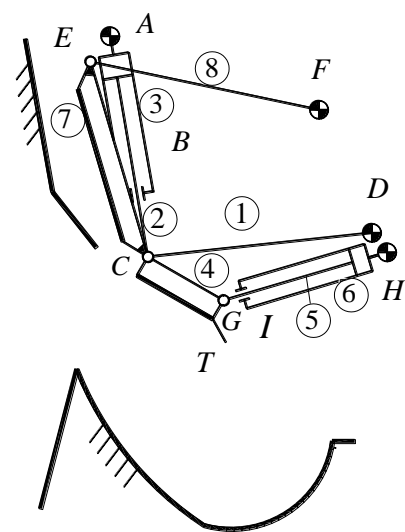

Fig. 2 – Kinematic scheme of the mechanism in the initial position

- Technological forces: \bar{Q} .

The points of reduction of force systems shall be considered in the centres of gravity G_4 , G_5 , and G_6 , corresponding to the elements 4, 5 and 6. The kinematic parameters of the points G_4 , G_5 , and G_6 are calculated using the procedure **A1R**, (Pelecudi Chr., 1975; Pelecudi Chr., Simionescu I., Moise V., Ene M., 1981).

The resulting inertial, gravity and reaction forces have the following form (Fig.3,b):

$$\bar{F}_{R4} = \bar{F}_{4X} + \bar{F}_{4Y}, \bar{F}_{R5} = \bar{F}_{5X} + \bar{F}_{5Y}, \bar{F}_{R6} = \bar{F}_{6X} + \bar{F}_{6Y} \tag{4}$$

where:

$$\bar{F}_{4X} = -m_4 \cdot \bar{a}_{G4X} + \bar{Q}_X ; \bar{F}_{4Y} = -m_4 \cdot (\bar{a}_{G4Y} + \bar{g}) + \bar{Q}_Y \tag{5}$$

$$\bar{F}_{5X} = -m_5 \cdot \bar{a}_{G5X}; \bar{F}_{5Y} = -m_5 \cdot (\bar{a}_{G5Y} + \bar{g}) \tag{6}$$

$$\bar{F}_{6X} = -m_6 \cdot \bar{a}_{G6X}; \bar{F}_{6Y} = -m_6 \cdot (\bar{a}_{G6Y} + \bar{g}) \tag{7}$$

In relation to the reduction points, the resulting moments are:

$$\bar{CM}_4 = -IG_4 \cdot \bar{\varepsilon}_4; \bar{CM}_5 = -IG_5 \cdot \bar{\varepsilon}_5; \bar{CM}_6 = -IG_6 \cdot \bar{\varepsilon}_6 \tag{8}$$

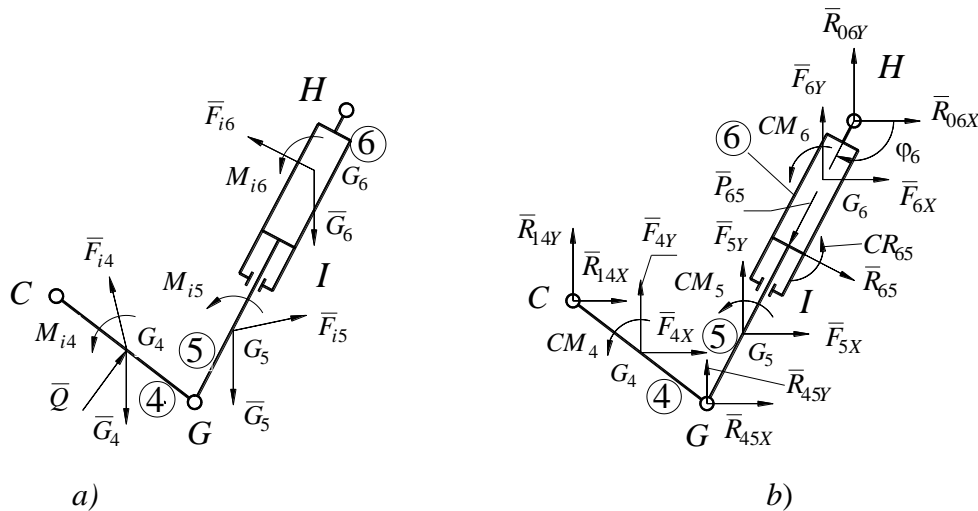

Fig. 3 – Motor groups RRTaR (4,5,6)

a) highlight of the forces and moments acting on the elements of the structural group
 b) kinetostatic scheme of the motor group RRTaR (4,5,6)

The reactions in the kinematic couplings of the motor groups, together with the acting force in the hydraulic cylinder, form the output data of the procedure **A2RC**.

Dyad RRR (7,8)

On the elements of the dyad RRR(7,8) act (Fig. 4,a):

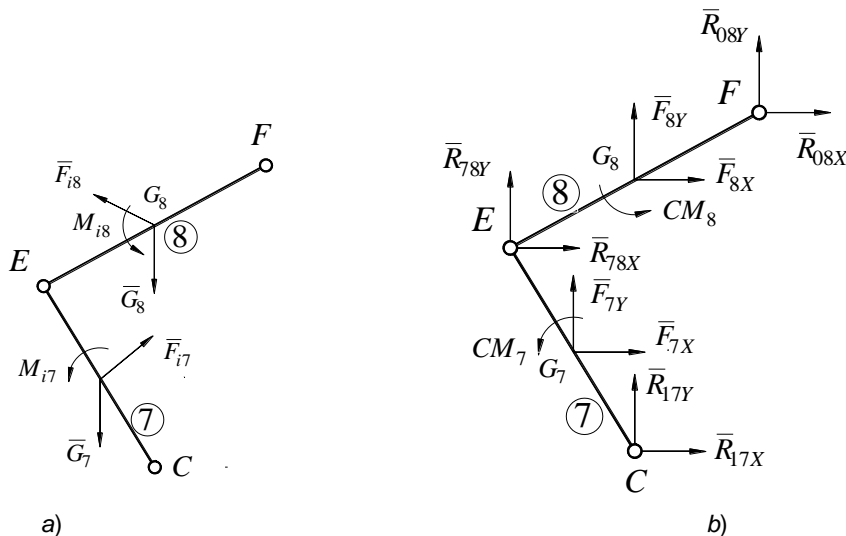

Fig. 4 - Dyad RRR (7,8)

a) highlighting the forces and moments acting on the elements of the structural group;
 b) kinetostatic scheme of the dyad RRR(7,8)

- gravity forces:

$$\bar{G}_7 = -m_7 \bar{g}, \bar{G}_8 = -m_8 \bar{g} \quad (9)$$

- inertial forces:

$$\bar{F}_{i7} = -m_7 \bar{a}_{G7}, \bar{F}_{i8} = -m_8 \bar{a}_{G8} \quad (10)$$

- the resultant moments of the inertial forces:

$$\bar{M}_{i7} = -IG_7 \cdot \bar{\varepsilon}_7, \bar{M}_{i8} = -IG_8 \cdot \bar{\varepsilon}_8 \quad (11)$$

The reduction points of the force systems shall be considered in the G_7 and G_8 gravity centres of elements 7 and 8. The kinematic parameters of these points are calculated using the **A1R** procedure.

The accelerations of the G_7 and G_8 reduction points of the force systems being known by the components on the coordinate axes, the inertial forces are:

$$\bar{F}_{i7} = F_{i7X} \bar{i} + F_{i7Y} \bar{j}, \bar{F}_{i8} = F_{i8X} \bar{i} + F_{i8Y} \bar{j} \quad (12)$$

The results of the applied, inertial and gravity forces are:

$$\bar{F}_{R7} = \bar{F}_{7X} + \bar{F}_{7Y}, \bar{F}_{R8} = \bar{F}_{8X} + \bar{F}_{8Y} \text{ (Fig. 3.6.9.b)} \quad (13)$$

where:

$$\bar{F}_{7X} = -m_7 \cdot \bar{a}_{G7X}; \bar{F}_{8Y} = -m_8 \cdot (\bar{a}_{G8Y} + \bar{g}) \quad (14)$$

$$\bar{F}_{8X} = -m_8 \cdot \bar{a}_{G8X}; \bar{F}_{8Y} = -m_8 \cdot (\bar{a}_{G8Y} + \bar{g}) \quad (15)$$

In relation to the reduction points, the resulting moments are:

$$\bar{CM}_7 = -IG_7 \cdot \bar{\varepsilon}_7, \bar{CM}_8 = -IG_8 \cdot \bar{\varepsilon}_8 \quad (16)$$

The reactions in the C, E and F kinematic couplings form the output data of the **D1RC** procedure.

Motor group RRTaR (1,2,3)

On the elements of the motor dyad $RRTaR (1,2,3)$ act (Fig. 5.a):

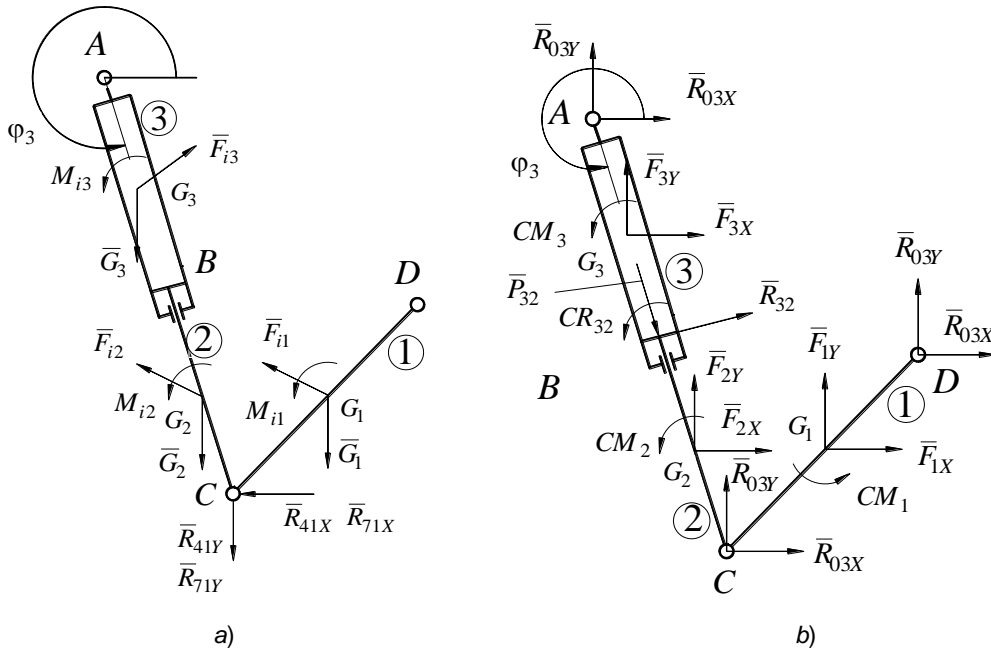

Fig. 5 - Motor group RRTaR (1,2,3)

a) highlight of the forces and moments acting on the elements of the structural group;

b) kinetostatic scheme of the motor dyad $RRTaR (1,2,3)$

- gravity forces:

$$\bar{G}_1 = -m_1 \bar{g}, \bar{G}_2 = -m_2 \bar{g}, \bar{G}_3 = -m_3 \bar{g} \quad (17)$$

- inertial forces:

$$\bar{F}_{i1} = -m_1 \bar{a}_{G1}, \bar{F}_{i2} = -m_2 \bar{a}_{G2}, \bar{F}_{i3} = -m_3 \bar{a}_{G3} \quad (18)$$

- the resultant moments of the inertial forces:

$$\bar{M}_{i1} = -IG_1 \cdot \bar{\varepsilon}_1, \bar{M}_{i2} = -IG_2 \cdot \bar{\varepsilon}_2, \bar{M}_{i3} = -IG_3 \cdot \bar{\varepsilon}_3 \quad (19)$$

- reactions of elements 4 and 7 on element 1 of the motor group $RRTaR(1,2,3)$, namely :
 $\bar{R}_{41X} = -\bar{R}_{14X}$, $\bar{R}_{41Y} = -\bar{R}_{14Y}$, $\bar{R}_{71X} = -\bar{R}_{17X}$, $\bar{R}_{71Y} = -\bar{R}_{17Y}$.

Points of reduction of system forces are considered in the centres of gravity G_1 , G_2 and G_3 , corresponding to the elements 1, 2 and 3.

Kinematic parameters of the points G_1 , G_2 and G_3 shall be calculated using the procedures **A1R** and **A1RALFA**.

The resultant inertial, gravity and reaction forces have the following form:

$$\bar{F}_{R1} = \bar{F}_{1X} + \bar{F}_{1Y}, \bar{F}_{R2} = \bar{F}_{2X} + \bar{F}_{2Y}, \bar{F}_{R3} = \bar{F}_{3X} + \bar{F}_{3Y} \quad (20)$$

where:

$$\bar{F}_{1X} = -m_1 \cdot \bar{a}_{G1X} + \bar{R}_{41X} + \bar{R}_{71X}; \bar{F}_{1Y} = -m_1 \cdot (\bar{a}_{G1Y} + \bar{g}) + \bar{R}_{41Y} + \bar{R}_{71Y} \quad (21)$$

$$\bar{F}_{2X} = -m_2 \cdot \bar{a}_{G2X}; \bar{F}_{2Y} = -m_2 \cdot (\bar{a}_{G2Y} + \bar{g}) \quad (22)$$

$$\bar{F}_{3X} = -m_3 \cdot \bar{a}_{G3X}; \bar{F}_{3Y} = -m_3 \cdot (\bar{a}_{G3Y} + \bar{g}) \quad (23)$$

In relation to the reduction points, the resulting moments are:

$$\bar{CM}_1 = -IG_1 \cdot \bar{\varepsilon}_1 + \bar{G}_1 \bar{C} \times (\bar{R}_{41X} + \bar{R}_{41Y}) + \bar{G}_1 \bar{C} \times (\bar{R}_{71X} + \bar{R}_{71Y}) \quad (24)$$

$$\bar{CM}_2 = -IG_2 \cdot \bar{\varepsilon}_2; \bar{CM}_3 = -IG_3 \cdot \bar{\varepsilon}_3 \quad (25)$$

The reactions in the kinematic couplings of the motor groups, together with the driving force in the hydraulic cylinder, form the existing data of procedure **A2RC**.

For the phases in which the hydraulic cylinder consisting of elements 2 and 3 is in action, the balancing force (driving force) in the active coupling B can also be calculated using the virtual exponent equation, namely:

$$\begin{aligned} \sum \bar{P} \cdot \bar{v} = & \bar{FE}_{32} \times \bar{v}_{32} + (\bar{F}_{i1} + \bar{G}_1) \cdot \bar{v}_{G1} + (\bar{F}_{i2} + \bar{G}_2) \cdot \bar{v}_{G2} + \\ & + (\bar{F}_{i3} + \bar{G}_3) \cdot \bar{v}_{G3} + (\bar{F}_{i4} + \bar{G}_4) \cdot \bar{v}_{G4} + (\bar{F}_{i5} + \bar{G}_5) \cdot \bar{v}_{G5} + \\ & + (\bar{F}_{i6} + \bar{G}_6) \cdot \bar{v}_{G6} + (\bar{F}_{i7} + \bar{G}_7) \cdot \bar{v}_{G7} + (\bar{F}_{i8} + \bar{G}_8) \cdot \bar{v}_{G8} + \\ & + \bar{M}_{i1} \cdot \bar{\omega}_1 + \bar{M}_{i2} \cdot \bar{\omega}_2 + \bar{M}_{i3} \cdot \bar{\omega}_3 + \bar{M}_{i4} \cdot \bar{\omega}_4 + \bar{M}_{i5} \cdot \bar{\omega}_5 + \\ & + \bar{M}_{i6} \cdot \bar{\omega}_6 + \bar{M}_{i7} \cdot \bar{\omega}_7 + \bar{M}_{i8} \cdot \bar{\omega}_8 = \bar{0} \end{aligned} \quad (26)$$

Using the above relationship, it results:

$$\begin{aligned} FE_{32} = & (m_1(a_{G1X} \cdot v_{G1X} + (a_{G1Y} + g) \cdot v_{G1Y} + IG_1 \cdot \omega_1 \cdot \varepsilon_1 + \\ & + m_2(a_{AG2X} \cdot v_{VG2X} + (a_{AG2Y} + g) \cdot v_{BY} + IG_2 \cdot \omega_2 \cdot \varepsilon_2 + \\ & + m_3(a_{G3X} \cdot v_{G3X} + (a_{G3Y} + g) \cdot v_{G3Y} + IG_3 \cdot \omega_2 \cdot \varepsilon_2 + \\ & + m_4(a_{G4X} \cdot v_{G4X} + (a_{G4Y} + g) \cdot v_{G4Y} + IG_4 \cdot \omega_4 \cdot \varepsilon_4 + \\ & + m_5(a_{G5X} \cdot v_{G5X} + (a_{G5Y} + g) \cdot v_{G5Y} + IG_5 \cdot \omega_5 \cdot \varepsilon_5 + \\ & + m_6(a_{G6X} \cdot v_{G6X} + (a_{G6Y} + g) \cdot v_{G6Y} + IG_6 \cdot \omega_6 \cdot \varepsilon_6 + \\ & + m_7(a_{G7X} \cdot v_{G7X} + (a_{G7Y} + g) \cdot v_{G7Y} + IG_7 \cdot \omega_7 \cdot \varepsilon_7 + \\ & + m_8(a_{G8X} \cdot v_{G8X} + (a_{G8Y} + g) \cdot v_{G8Y} + IG_8 \cdot \omega_8 \cdot \varepsilon_{87} - \\ & - Q \cdot \cos(\varphi_4 + \pi/2) \cdot v_{G4X} - Q \cdot \sin(\varphi_4 + \pi/2) \cdot v_{G4Y}) / v_{32}. \end{aligned} \quad (27)$$

For phases in which the hydraulic cylinder consisting of elements 5 and 6 is in action, the balancing force (driving force) in the active coupling may be calculated using the relationship:

$$\begin{aligned} \sum \bar{P} \cdot \bar{v} = & \bar{FE}_{65} \times \bar{v}_{65} + (\bar{F}_{i1} + \bar{G}_1) \cdot \bar{v}_{G1} + (\bar{F}_{i2} + \bar{G}_2) \cdot \bar{v}_{G2} + \\ & + (\bar{F}_{i3} + \bar{G}_3) \cdot \bar{v}_{G3} + (\bar{F}_{i4} + \bar{G}_4) \cdot \bar{v}_{G4} + (\bar{F}_{i5} + \bar{G}_5) \cdot \bar{v}_{G5} + \\ & + (\bar{F}_{i6} + \bar{G}_6) \cdot \bar{v}_{G6} + (\bar{F}_{i7} + \bar{G}_7) \cdot \bar{v}_{G7} + (\bar{F}_{i8} + \bar{G}_8) \cdot \bar{v}_{G8} + \\ & + \bar{M}_{i1} \cdot \bar{\omega}_1 + \bar{M}_{i2} \cdot \bar{\omega}_2 + \bar{M}_{i3} \cdot \bar{\omega}_3 + \bar{M}_{i4} \cdot \bar{\omega}_4 + \bar{M}_{i5} \cdot \bar{\omega}_5 + \\ & + \bar{M}_{i6} \cdot \bar{\omega}_6 + \bar{M}_{i7} \cdot \bar{\omega}_7 + \bar{M}_{i8} \cdot \bar{\omega}_8 = \bar{0} \end{aligned} \quad (28)$$

Using the above relationship, it results:

$$\begin{aligned}
 FE_{65} = & (m_1(a_{G1X} \cdot v_{G1X} + (a_{G1Y} + g) \cdot v_{G1Y} + IG_1 \cdot \omega_1 \cdot \varepsilon_1 + \\
 & + m_2(a_{G2X} \cdot v_{G2X} + (a_{G2Y} + g) \cdot v_{G2Y} + IG_2 \cdot \omega_2 \cdot \varepsilon_2 + \\
 & + m_3(a_{G3X} \cdot v_{G3X} + (a_{G3Y} + g) \cdot v_{G3Y} + IG_3 \cdot \omega_3 \cdot \varepsilon_3 + \\
 & + m_4(a_{G4X} \cdot v_{G4X} + (a_{G4Y} + g) \cdot v_{G4Y} + IG_4 \cdot \omega_4 \cdot \varepsilon_4 + \\
 & + m_5(a_{G5X} \cdot v_{G5X} + (a_{G5Y} + g) \cdot v_{G5Y} + IG_5 \cdot \omega_5 \cdot \varepsilon_5 + \\
 & + m_6(a_{G6X} \cdot v_{G6X} + (a_{G6Y} + g) \cdot v_{G6Y} + IG_6 \cdot \omega_6 \cdot \varepsilon_6 + \\
 & + m_7(a_{G7X} \cdot v_{G7X} + (a_{G7Y} + g) \cdot v_{G7Y} + IG_7 \cdot \omega_7 \cdot \varepsilon_7 + \\
 & + m_8(a_{G8X} \cdot v_{G8X} + (a_{G8Y} + g) \cdot v_{G8Y} + IG_8 \cdot \omega_8 \cdot \varepsilon_8 - \\
 & - Q \cdot \cos(\phi_4 + \pi/2) \cdot v_{G4X} - Q \cdot \sin(\phi_4 + \pi/2) \cdot v_{G4Y})) / v_{65}.
 \end{aligned}
 \tag{29}$$

RESULTS

Applying the theoretical method described below, by simulating the working process of a machine, designed to collect the municipal waste, for appropriate constructive dimensions, the results obtained are presented.

For the kinetostatic analysis of the mechanism we used:

- a) The kinematic scheme of the mechanism (Fig.1);
- b) The positions of the coupling adjacent to the base and dimensions of the elements as follows: $XA = 0$ m, $YA = 0$ m, $XD = 1.000$ m, $YD = -0.733$ m, $XF = 0.800$ m, $YF = -0.270$ m, $XH = 1.100$ m, $YH = -0.800$ m, $CE = 0.770$ m, $CD = 0.870$ m, $EF = 0.900$ m; $CG = 0.330$ m;
- c) Phase working times: $t_1 = 5$ sec, $t_2 = 5$ sec, $t_3 = 5$ sec, $t_4 = 5$ sec,
- d) Initial position of the mechanism: $S_{230} = 0.833$ m, $S_{560} = 0.667$ m;
- e) Hydraulic cylinder piston work: $stroke_{23} = 0.600$ m, $stroke_{56} = 0.400$ m;
- f) Hydraulic cylinder piston road lengths: $d_2 = 0.700$ m, $d_5 = 0.550$ m;
- g) Transmission function used for hydraulic cylinder actuation: sinusoidal function $l \sin$;
- h) The masses of the mechanism elements: $m_1 = 10.0$ kg, $m_2 = 5.0$ kg, $m_3 = 10.0$ kg, $m_4 = 20.0$ kg, $m_5 = 5.0$ kg, $m_6 = 10.0$ kg, $m_7 = 20$ kg; $m_8 = 20$ kg;
- i) Position of the mass centres: $DG_1 = CD/2$, $CG_2 = d_2/2$ m, $AG_3 = 0.4$ m, $CG_4 = CG/2$ m, $CG_5 = d_5 / 2$ m, $AG_6 = AD/2$ m, $FG_7 = 0.3$ m, $EG_8 = 0.3$ m;
- j) Inertial moments of elements: $I_{G1} = 0.6$ kgm², $I_{G2} = 0.2$ kgm², $I_{G3} = 1.1$ kgm², $I_{G4} = 0.2$ kgm², $I_{G5} = 0.3$ kg m²; $I_{G6} = 0.35$ kg, $I_{G7} = 1.0$ kg; $I_{G8} = 0.9$ kg;
- k) Technological strength:
 - $Q = 1000$ N, for branches *cb* and *cd* of the diagram in figure 2;
 - $Q = 0$ N, for branches *ab* and *da* of the diagram in figure 2.

In figures 6 and 7, the hodographs of the reactions in the *D* and *A* joints are presented.

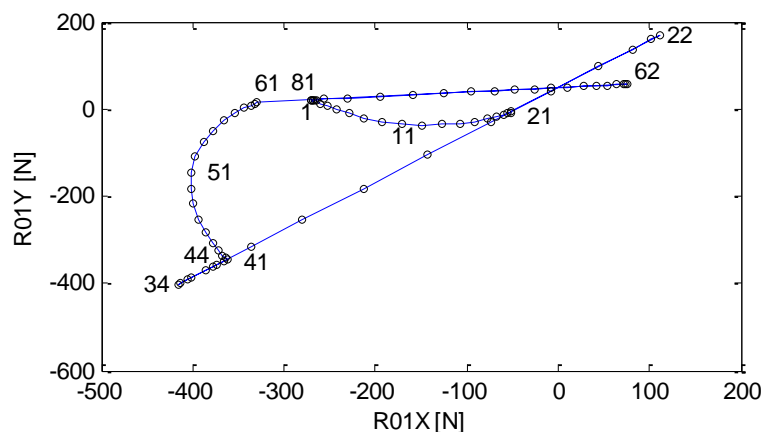

Fig. 6 – The hodograph of reactions in *D* joint

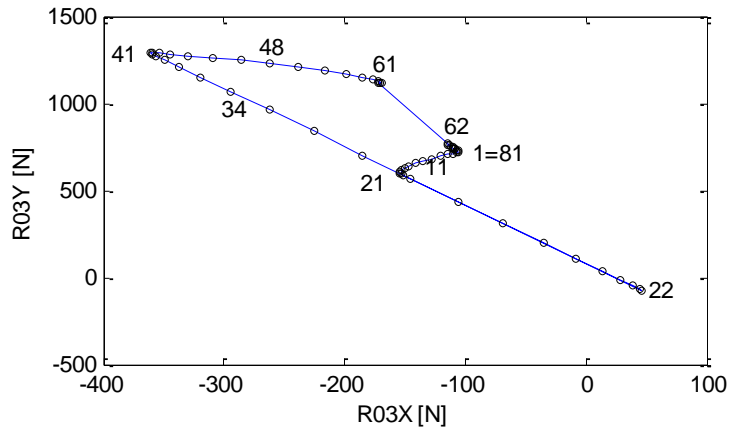

Fig. 7 – The hodograph of reactions in A joint

The diagrams of the driving forces in the hydraulic cylinders formed with elements 2 and 3, respectively 5 and 6, depending on the position of the mechanism, are shown in figures 8a and 8b.

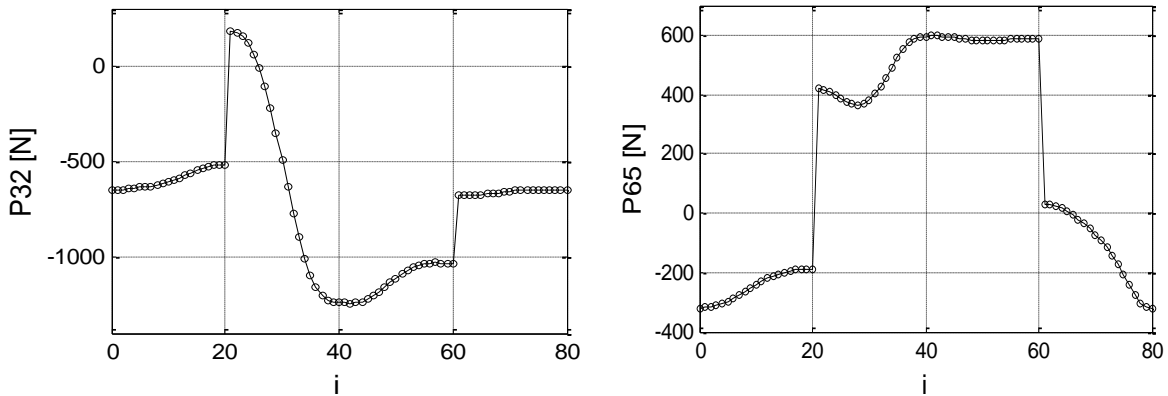

Fig. 8 – Driving force diagram

(a) from the hydraulic cylinder 2-3 ; (b) – from the hydraulic cylinder 5-6

Table 1 shows the size of the components on the coordinate axes of the reactions in the D and H kinematic couplings, depending on the position of the mechanism.

Table 1

Poz	R03X	R03Y	R01X	R01Y	R06X	R06Y
0	-109.94	741.26	-270.33	21.23	319.51	133.34
1	-109.47	738.49	-269.12	21.12	318.27	133.21
2	-108.83	735.68	-267.31	20.18	316.04	134.08
3	-107.95	732.80	-264.33	17.71	311.97	136.80
4	-106.91	729.80	-259.54	13.26	305.42	141.96
5	-106.03	726.56	-252.32	6.71	296.07	149.74
6	-105.84	722.86	-242.13	-1.57	283.88	159.90
7	-106.92	718.33	-228.63	-10.84	269.10	171.86
8	-109.70	712.50	-211.86	-20.03	252.22	184.80
9	-114.27	704.89	-192.29	-27.98	233.84	197.85
10	-120.37	695.14	-170.84	-33.67	214.68	210.20
11	-127.38	683.21	-148.70	-36.45	195.53	221.19
.....						
59	-171.60	1118.15	-329.85	14.84	-550.33	-111.01
60	-172.11	1121.07	-329.41	15.15	-550.80	-110.73
61	-114.07	766.47	75.80	56.85	-21.98	72.42
62	-114.00	766.04	74.42	56.71	-20.20	72.94
.....						
79	-109.81	740.44	-267.56	21.52	316.33	132.87
80	-109.94	741.26	-270.33	21.23	319.51	133.34

CONCLUSIONS

The values obtained for the reaction forces, through the kinematic analysis of the mechanism, allow proceeding to the next stage, i.e. the real design of the kinematic elements.

To verify the results obtained by kinematic analysis, the driving forces in the hydraulic cylinders and the method of virtual exponents were determined and the results were identical to those in the kinetostatic calculations. Depending on the driving forces in the hydraulic cylinders, we can choose the cylinders from the producers' constructive offer.

For collecting and compacting waste, the constructive form of the kinematic elements can be chosen by machine designers.

ACKNOWLEDGEMENT

Part of this paper was funded by the European Social Fund from the Sectoral Operational Programme Human Capital 2014-2020, through the Financial Agreement with the title "Scholarships for entrepreneurial education among doctoral students and postdoctoral researchers (Be Entrepreneur!)", Contract no. 51680/09.07.2019 - SMIS code: 124539.

REFERENCES

- [1] Artobolevski I.I., (1977), *Theory of mechanisms and machines (Theorie des mecanismes et des machines)*, 453 p., Mir Publishing House, Moscow / Russia;
- [2] Demidovitch B., Maron I., (1987), *Elements of numerical calculation (Elements de calcul numerique)*. 717 p., Mir Publishing House, Moscow / Russia;
- [3] Dorn W.S., Mc Cracken D.D., (1976), *Numerical methods with Fortran*, 468 p., Technical Publishing House, Bucharest / Romania;
- [4] Duca C., Buium Fl., Părăoanu G., (2003), *Mechanisms*, 481 p., Gh. Asachi Publ. House, Iasi/ Romania;
- [5] Moise V., Maican E., Moise Șt. I., (2003), *Numerical method in engineering*, 305 p., Bren Publishing House, Bucharest / Romania;
- [6] Moise V., Simionescu I., Ene M., Neacșa M., Tabără I.A., (2008), *Analysis of applied mechanisms*, 282 p., Printech Publishing House, Bucharest / Romania;
- [7] Moise V., Simionescu I., Ene M., Rotaru Al., (2015), *Analysis of plane mechanisms with articulated bars. Applications in MATLAB*, Printech Publishing House, Bucharest / Romania;
- [8] Moise V., Maican E., Moise Șt.I., (2016), *Numerical methods. Applications in MATLAB*, Printech Publishing House, Bucharest / Romania;
- [9] Moise V., Simionescu I., Ene M., (2018), *Optimal synthesis of flat cam mechanisms*, Printech Publishing House, Bucharest / Romania;
- [10] Pelecudi Chr., (1975), *Precision of the mechanism*, 398 p., Publishing House of the Academy of the Socialist Republic of Romania, Bucharest / Romania;
- [11] Pelecudi Chr., Simionescu I., Moise V., Ene M., (1981), *Design of mechanism*. Polytechnic Institute of Bucharest / Romania;
- [12] Pelecudi Chr., Maroș D., Merticaru V., Pandrea N., Simionescu I., (1985), *Mechanisms*, 394 p., Didactic and Pedagogical Publishing House Bucharest / Romania;
- [13] Simionescu I., Moise V., (1999), *Mechanisms*, 238 p., Technical Publishing House, Bucharest / Romania;
- [14] Voicu Gh., Lazea M., Zabava B.S., Tudor P., Moise V., (2019), Kinematic analysis of the pre-taking and pre-compacting mechanisms of some garbage trucks, *Journal of Engineering Studies and Research*, Vol. 25, No. 2, pp.56-62, Bacau / Romania;
- [15] Voicu Gh., Lazea M., Tudor P., Zabava B.St., Moise V., (2019), Comparative analysis of the municipal waste collection and pre-compacting systems, *Sixth International Conference Research people and actual tasks on multidisciplinary sciences*, pp.354-359, Lozenec / Bulgaria.